



M Series 4.5-Compact 12ton IC Forklift



M Series Forklift Truck



Maximal Forklift (Zhejiang) Co., Ltd

Address No.1, jinxin Road, Lushan Industrial area, Fuyang, Zhejiang China

Tel 0086-571-28001570

0086-571-28935028

0086-571-28979902

Fax 0086-571-28001569

Email

For sales

info@maxforklift.com

For spare parts

parts@maxforklift.com

All rights reserved.

If any doubt, please contact us.



maxixem

MAXIMAL FAMILY

- M Series 1.5-3.2T diesel forklift
- A series 2.5-3.5T diesel forklift
- M series 1.5-7T gasoline /LPG forklift
- A series 2.5-3.5T gasoline /LPG forklift
- M series 4-5T 4-wheel electric forklift
- A series 1.5-3.5T 4-wheel electric forklift
- M series 1.6-2T 3-wheel electric forklift
- A series 1.6-2.5T electric reach truck
- M series 1.6T Rear drive 3-wheel electric forklift
- M series 2.5T Dual drive 4-wheel electric forklift
- M series 0.7-1.5T VNA truck
- M series 2.5T cushion tyre forklift
- M series 1.8-3.5T compact 4WD rough terrain forklift
- M series 1.3-3T Omni-Directional electric forklift
- M series 2.5-3.5T 4WD rough terrain forklift
- 9T empty container handler
- M series 1.8-5.0T 2WD rough terrain forklift
- 4.5T reach stacker
- 3.5-4.5T side loader forklift

We work for maximal



Maximal Company Introduction



Established in Feb. 2006, Maximal Forklift (zhejiang) Co., Ltd, is located in Lushan Industry Area with convenient transportation. Maximal specializes in material handling equipment designing and manufacturing.

Maximal Company total floor area is 133,334 m², investment RMB420 million, factory designed production capacity is 30000 units per year.

Currently Maximal employs 500 staffs, with more than 230 professional and technical personnel, more than 70 Technical R&D personnel. Maximal gained 7 national invention patents, more than 70 utility model and appearance patents.

Maximal owns advanced parts processing center, robot welding equipments, parts automatic hoist conveyor lines, coating lines, assembly lines, forklifts performance test lines, parts test-bed and ERP information management system.

Maximal current product range covers 4 series, including 1.5-compact 1.2T industrial forklift, 1.8-5.0T rough terrain forklift, 13.5-32.0T heavy duty forklift & Port machinery and warehouse equipment.

Maximal forklifts received strong public recognition for their modern and striking appearance, high production quality, safety standard and low cost of operation.

At present, Maximal products sales have covered all provinces in domestic market, exported to over 100 countries and areas. Maximal takes "technology innovation, promoting products structure, improving product quality and service" as the belief, takes internationalization, professionalization and green environmental protection as mission, to build Maximal into the most respectable forklift brand.

Current products consist of:

M series:

- 1.5-3.2T/3000-64,000LB capacity diesel forklifts.
- 1.5-7T/3000-14,000LB capacity gasoline/LPG forklifts.
- 4-5T/8000-10,000LB capacity 4-wheel electric forklifts.
- 1.6-2T/3200-4000LB capacity 3-wheel electric forklifts.
- 0.7-1.5T/1400-3000LB capacity VNA truck.
- 1.6T/3200LB capacity Rear drive 3-wheel electric forklifts.
- 2.5T/4000-5000LB capacity dual-drive 4-wheel electric forklifts.
- 2.5T/4000-5000LB capacity cushion tyre forklifts.
- 1.3-3T/2600-6000LB capacity Omni-Directional electric forklifts.

A series:

- 2.5-3.5T/4000-7000LB capacity diesel and gasoline/LPG forklifts.

- 1.5-3.5T/3000-7000LB capacity 4-wheel electric forklifts.
- 1.6-2.5T/3200-5000LB capacity electric reach truck.

Rough Terrain:

- 1.8-3.5T/3600-7000LB capacity compact 4WD rough terrain forklifts.
- 2.5-3.5T/5000-7000LB capacity 4WD rough terrain forklifts.
- 1.8-5.0T/3600-10,000LB capacity 2WD rough terrain forklifts.

Port Machinery:

- 9T/18,000LB capacity empty container handler.
- 45T/90,000LB capacity reach stacker.

Side Loader Forklift:

- 3.5T-4.5T/7000-9900LB capacity side loader forklifts.

M series introduction

The M series is the first generation forklifts, designed by the MAXIMAL engineering team. A world class design is featured as advanced technologies and superior componentry produced by competitive vendors over the world. The finished appearance with safety color design has attracted an audience in local and the world markets.

Classification of After-sales Service

Classification of After-sales Service classifies customer claims into 3 classes, Warranty 1(W1), Warranty 2(W2), Warranty 3(W3). Different claim class has different after-sales procedures which aims to increase service quality.



Classification of After-sales Service



24-hour fast reply on trucks and parts claims



Ergonomic design



High quality components



Safety operation





M SERIES 4.5-compact 5.0t diesel forklift

General	1	Model		FD45T-M1 WI3	FD50T-M1 WI3		
	2	Type		Diesel			
	3	Optional type		W(1)3/G(21)3/ W(13)3			
Characteristic&Dimension	4	Rated capacity	kg	4500	5000		
	5	Load centre	mm	500	500		
	6	Lift height	mm	3000	3000		
	7	Free lift height	mm	150	155		
	8	Fork size	L×W×T	mm	1070×150×50	1070×150×55	
	9	Fork regulating range	Min./Max.	mm	300/1380	300/1380	
	10	Mast tilt angle	F/R	Deg	6/12	6/12	
	11	Front overhang		mm	590	595	
	12	Rear overhang		mm	585	625	
	13	Min. ground clearance(Bottom of mast)		mm	175	175	
	Overall dimensions	14		Length to face of fork (without fork)	mm	3260	3310
		15		Overall width	mm	1490	1490
		16		Mast lowered height	mm	2265	2265
		17		Mast extended height(with backrest)	mm	4230	4230
18		Overhead guard height		mm	2265	2265	
19	Turning radius(outside)		mm	2920	2960		
Performance	20	Min. right angle stacking aisle width (add load length and clearance)		mm	2600	2630	
	Speed	21	Travel(Unladen)	km/h	25	25	
		22	Lifting(Laden)	mm/s	515	515	
		23	Lowering(Laden)	mm/s	400	400	
	24	Max. Drawbar pull(Laden)	KN	23	23		
25	Max. Gradeability(Laden)	%	20	18			
Tyre	26	Tyre	Front	300-15-18PR			
	27		Rear	7.00-12-12PR			
	Tread	28	Front	mm	1190		
		29	Rear	mm	1130		
	30	Wheelbase	mm	2100			
Weight	31	Fuel tank capacity	L	120			
	32	Self weight	kg	6500	6720		
	Weight Distribution	Laden	33	Front Axle	kg	9650	10320
			34	Rear Axle	kg	1350	1400
		Unladen	35	Front Axle	kg	2840	2960
			36	Rear Axle	kg	3660	3760
Power&Transmission	37	Battery	Voltage/Capacity	V/Ah	2×12/60		
	38		Manufacture		China		
	Transmission	39	Type			Powershift	
		40	Stage	F/R		2/1	
	41	Operating pressure(For attachments)	MPa		19		

M SERIES 4.5-compact 5.0t LPG forklift

General	1	Model		FL45T-M1 WE3	FL50T-M1 WE3		
	2	Type		LPG			
	3	Optional type		W(J1)3			
Characteristic&Dimension	4	Rated capacity		4500	5000		
	5	Load centre	kg	500	500		
	6	Lift height	mm	3000	3000		
	7	Free lift height		150	155		
	8	Fork size	L×W×T	mm	1070×150×50	1070×150×55	
	9	Fork regulating range	Min./Max.	mm	300/1380	300/1380	
	10	Mast tilt angle	F/R	Deg	6/12	6/12	
	11	Front overhang		mm	590	595	
	12	Rear overhang		mm	585	625	
	13	Min. ground clearance(Bottom of mast)		mm	175	175	
	Overall dimensions	14		Length to face of fork (without fork)	mm	3260	3310
		15		Overall width	mm	1490	1490
		16		Mast lowered height	mm	2265	2265
		17		Mast extended height(with backrest)	mm	4230	4230
18		Overhead guard height		mm	2265	2265	
19	Turning radius(outside)		mm	2920	2960		
Performance	20	Min. right angle aisle width (add load length and clearance)		mm	2600	2630	
	Speed	21	Travel(Unladen)	km/h	22	22	
		22	Lifting(Laden)	mm/s	440	440	
		23	Lowering(Laden)	mm/s	400	400	
	24	Max. Drawbar pull(Laden)	KN	23	23		
25	Max. Gradeability(Laden)	%	18	15			
Tyre	26	Tyre	Front	300-15-18PR			
	27		Rear	7.00-12-12PR			
	Tread	28	Front	mm	1190		
		29	Rear	mm	1130		
	30	Wheelbase	mm	2100			
Weight	31	Fuel tank capacity	L	120			
	32	Self weight	kg	6500	6720		
	Weight Distribution	Laden	33	Front Axle	kg	9650	10320
			34	Rear Axle	kg	1350	1400
		Unladen	35	Front Axle	kg	2840	2960
			36	Rear Axle	kg	3660	3760
Power&Transmission	37	Battery	Voltage/Capacity	V/Ah	12/60		
	38		Manufacture		China		
	Transmission	39	Type			Powershift	
		40	Stage	F/R		1/1	
	41	Operating pressure(For attachments)	MPa		19		



MITSUBISHI
 Type: W13
 Model: S6S(Eu III)
 Rated output: 52kw/2450rpm
 Rated torque: 250 N.m / 1600rpm
 No. of cylinder: 6
 Bore x Stroke: 94 x 120mm
 Displacement: 4.996L

DEUTZ
 Type: W (1) 3
 Model: TD2.9 L4 (Eu IV)
 Rated output: 55.4kw/2600rpm
 Rated torque: 260 N.m / 1800rpm
 No. of cylinder: 4
 Bore x Stroke: 92 x 101mm
 Displacement: 2.9L

KUBOTA
 Type: W(13) 3
 Model: V3800(Eu V+Tier4)
 Rated output: 54.6kw/2200rpm
 Rated torque: 305.4 N.m / 1500rpm
 No. of cylinder: 4
 Bore x Stroke: 100 x 120 mm
 Displacement: 3.769L

QUANCHAI
 Type: G(21)3
 Model: 4C6-85U32
 Rated output: 60kw/2200rpm
 Rated torque: 330 N.m / 1800rpm
 No. of cylinder: 4
 Bore x Stroke: 98 x 115mm
 Displacement: 3.12L

PSI
 Type: WE3
 Model: PS14.3L
 Rated output: 63kw/2000rpm
 Rated torque: 298 N.m / 1200rpm
 No. of cylinder: 6
 Bore x Stroke: 101.6 x 88.39mm
 Displacement: 4.3L

KUBOTA
 Type: W(J3) 3
 Model: WG3800(Eu V)
 Rated output: 54.6kw/2400rpm
 Rated torque: GAS 246.8 N.m / 1500rpm
 LPG 271.4 N.m / 1200rpm
 No. of cylinder: 4
 Bore x Stroke: 100 x 120 mm
 Displacement: 3.769L

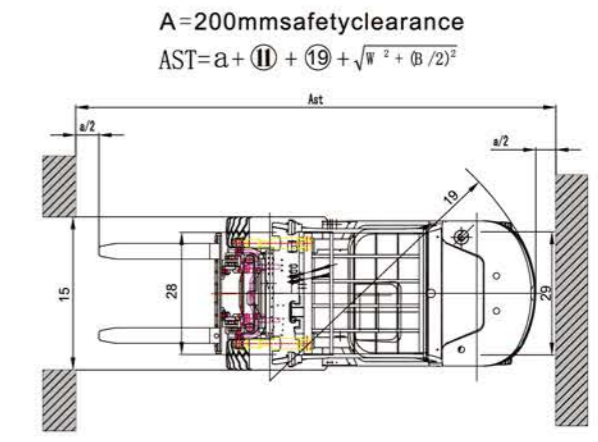
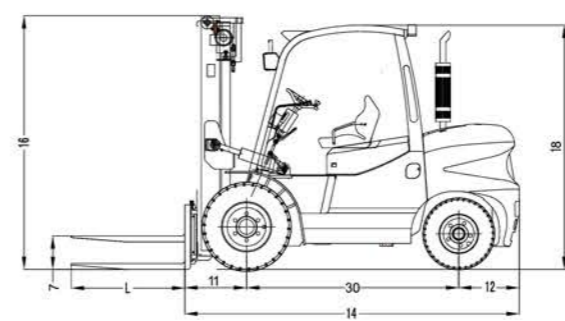
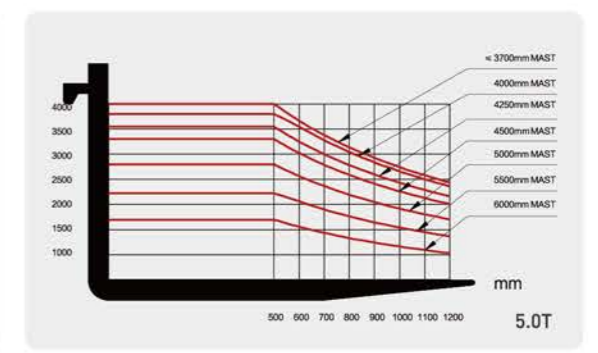
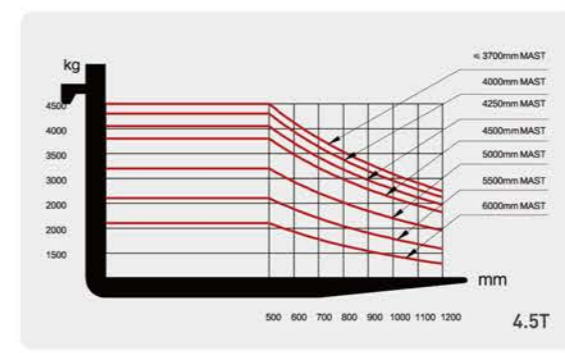
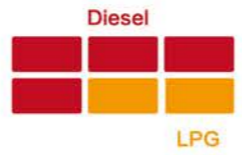

M SERIES 4.5-compact 5.0t mast

Type	Model	Max. fork height	Overall height						Free lift				Front Overhang		Tilt range		Capacity	
			Lowered		Extended				Without backrest		with backrest		4.5t	compact5t	FWD	BWD	load capacity at 500mm	
			4.5t	compact5t	Without backrest	With backrest	4.5t	5t	4.5t	5t	4.5t	compact5t					kg	compact5t
2-stage mast	M330	3300	2415	2415	4130	4130	4520	4520	150	155	150	155	590	595	6	12	4500	5000
	M350	3500	2515	2515	4330	4330	4720	4720	150	155	150	155	590	595	6	12	4500	5000
	M370	3700	2615	2615	4530	4530	4920	4920	150	155	150	155	590	595	6	12	4500	5000
	M400	4000	2815	2815	4830	4830	5220	5220	150	155	150	155	590	595	6	6	4300	4800
	M450	4500	3065	3065	5330	5330	5720	5720	150	155	150	155	590	595	6	6	3800	4200
	M500	5000	3315	3315	5830	5830	6220	6220	150	155	150	155	590	595	6	6	3200	3600
	M550	5500	3615	3615	6330	6330	6720	6720	150	155	150	155	590	595	3	6	2600	2950
Full free 2-stage mast	FM300	3000	2385	2385	3840	3840	4220	4220	1545	1165	600	605	6	12	4500	5000		
	FM330	3300	2535	2535	4140	4140	4520	4520	1695	1315	600	605	6	12	4500	5000		
	FM350	3500	2635	2635	4340	4340	4720	4720	1795	1415	600	605	6	12	4500	5000		
Full free 3-stage mast	TFM392	3920	2240	2240	4760	4760	5140	5140	1400	1020	630	635	6	6	4000	4500		
	TFM435	4350	2385	2385	5190	5190	5570	5570	1545	1165	630	635	6	6	3800	4200		
	TFM450	4500	2436	2436	5340	5340	5720	5720	1595	1216	630	635	6	6	3700	4100		
	TFM480	4800	2535	2535	5640	5640	6020	6020	1695	1315	630	635	6	6	3400	3800		
	TFM500	5000	2635	2635	5840	5840	6220	6220	1795	1415	630	635	6	6	3100	3500		
	TFM540	5400	2760	2760	6240	6240	6620	6620	1920	1540	630	635	3	6	2500	2850		
	TFM600	6000	3000	3000	6840	6840	7220	7220	2160	1780	630	635	3	6	2000	2300		
TFM650	6500	3215	3215	7340	7340	7720	7720	2375	1995	630	635	3	6	1500	1700			





M SERIES 5.0-7.0t diesel forklift

General	1	Model	FD50T-M WJ3	FD70T-M WJ3			
	2	Type	Diesel				
	3	Optional type	WL3/WY3/WF3/G(4)3/ W(13)3				
Characteristic&Dimension	4	Rated capacity	kg	5000	7000		
	5	Load centre	mm	600	600		
	6	Lift height	mm	3000	3000		
	7	Free lift height	mm	195	205		
	8	Fork size	L×W×T	mm	1220×150×55	1220×150×65	
	9	Fork regulating range	Min./Max.	mm	300/1845	300/1845	
	10	Mast tilt angle	F/R	Deg	6°/12°	6°/12°	
	11	Front overhang	mm	580	590		
	12	Rear overhang	mm	600	740		
	13	Min. ground clearance(Bottom of mast)	mm	200	200		
	Overall dimensions	14	Overall dimensions	Length to face of fork (without fork)	mm	3440	3580
		15		Overall width	mm	1995	1995
		16		Mast lowered height	mm	2500	2625
		17		Mast extended height(with backrest)	mm	4370	4370
		18		Overhead guard height	mm	2435	2435
	19	Turning radius(outside)	mm	3250	3370		
	Performance	20	Min. right angle stacking aisle width (add load length and clearance)	mm	2960	3040	
		21-23	Speed	Travel(Laden/Unladen)	km/h	24/26	24/26
				Lifting(Laden/Unladen)	mm/s	400/420	380/400
Lowering(Laden)				mm/s	500	500	
24	Max. Drawbar pull(Laden)	KN	53	49			
25	Max. Gradeability(Laden)	%	15	17			
Tyre	26-27	Tyre	Front		8.25-15-14PR	8.25-15-14PR	
			Rear		8.25-15-14PR	8.25-15-14PR	
	28-29	Tread	Front	mm	1470	1470	
			Rear	mm	1700	1700	
Weight	30	Wheelbase	mm	2250	2250		
	31	Self weight	kg	8080	9450		
	32-35	Weight Distribution	Laden	Front Axle	kg	11250	14150
				Rear Axle	kg	1830	2300
			Unladen	Front Axle	kg	3640	4250
				Rear Axle	kg	4440	5200
Power&Transmission	36	Battery	Voltage/Capacity	V/Ah	2×12/80		
	37	Transmission	Manufacture		China		
	38		Type		Powershift		
	39		Stage	F/R		2/2	
	40	Operating pressure(For attachments)	MPa		19.5		

M SERIES 5.0-7.0t LPG forklift

General	1	Model	FL50T-M WE3	FL70T-M WE3			
	2	Type	LPG				
	3	Optional type	/				
Characteristic&Dimension	4	Rated capacity	kg	5000	7000		
	5	Load centre	mm	600	600		
	6	Lift height	mm	3000	3000		
	7	Free lift height	mm	195	205		
	8	Fork size	L×W×T	mm	1220×150×55	1220×150×65	
	9	Fork regulating range	Min./Max.	mm	300/1845	300/1845	
	10	Mast tilt angle	F/R	Deg	6°/12°	6°/12°	
	11	Front overhang	mm	580	590		
	12	Rear overhang	mm	600	740		
	13	Min. ground clearance(Bottom of mast)	mm	200	200		
	Overall dimensions	14	Overall dimensions	Length to face of fork (without fork)	mm	3440	3580
		15		Overall width	mm	1995	1995
		16		Mast lowered height	mm	2500	2625
		17		Mast extended height(with backrest)	mm	4370	4370
		18		Overhead guard height	mm	2435	2435
	19	Turning radius(outside)	mm	3250	3370		
	Performance	20	Min. right angle aisle width (add load length and clearance)	mm	2960	3040	
		21-23	Speed	Travel(Laden/Unladen)	km/h	19/20	19/20
				Lifting(Laden/Unladen)	mm/s	400/420	380/400
Lowering(Laden)				mm/s	500	500	
24	Max. Drawbar pull(Laden)	KN	53	52			
25	Max. Gradeability(Laden)	%	15	15			
Tyre	26-27	Tyre	Front		8.25-15-14PR	8.25-15-14PR	
			Rear		8.25-15-14PR	8.25-15-14PR	
	28-29	Tread	Front	mm	1470	1470	
			Rear	mm	1700	1700	
Weight	30	Wheelbase	mm	2250	2250		
	31	Self weight	kg	8080	9450		
	32-35	Weight Distribution	Laden	Front	kg	11250	14150
				Rear	kg	1830	2300
			Unladen	Front	kg	3640	4250
				Rear	kg	4440	5200
Power&Transmission	36	Battery	Voltage/Capacity	V/Ah	2×12/60		
	37	Transmission	Manufacture		China		
	38		Type		Hyd		
	39		Stage	F/R		2/2	
	40	Operating pressure(For attachments)	MPa		19.5		

MITSUBISHI
 Type: WJ3
 Model: S6S-T(EuIIIA)
 Rated output: 63.9kw/2300kw/rpm
 Rated torque: 293N·m/1700rpm
 No. of cylinder:6
 Bore × Stroke:94 × 120mm
 Displacement:4.996L

DEUTZ
 Type: WY3
 Model: TCD3.6L4 (Eu IV)
 Rated output: 55.4kw/2300rpm
 Rated torque: 390 N·m / 1300rpm
 No. of cylinder: 4
 Bore × Stroke: 98x120mm
 Displacement: 6.494L

ISUZU
 Type: WF3
 Model: 6BG1QC
 Rated output: 82kw/2000rpm
 Rated torque: 416N.m/1400-1600rpm
 No. of cylinder: 6
 Bore × Stroke: 105x125mm
 Displacement: 6.494L

CHAOCHAI
 Type: G(4)3
 Model: CY6BG332
 Rated output: 85kw/2200rpm
 Rated torque: 450N.m / 1400-1800rpm
 No. of cylinder: 6
 Bore × Stroke: 102x118mm
 Displacement: 5.785L

CUMMINS
 Type: WL3
 Model: QSB4.5(EuIIIA)
 Rated output: 80.9kw/2200rpm
 Rated torque: 488 N.m / 1500rpm
 No. of cylinder: 4
 Bore × Stroke: 107 × 124mm
 Displacement: 4.5L

PSI
 Type: WE3
 Model: PSI4.3L
 Rated output: 63kw/2000rpm
 Rated torque: 298 N.m / 1200rpm
 No. of cylinder: 6
 Bore × Stroke: 101.6 × 88.39mm
 Displacement: 4.3L

KUBOTA
 Type: W(13)3
 Model: V3800(Eu V+Tier4)
 Rated output: 54.6kw/2200rpm
 Rated torque: 305.4 N.m / 1500rpm
 No. of cylinder: 4
 Bore × Stroke: 100 × 120 mm
 Displacement: 3.769L
COMING SOON!

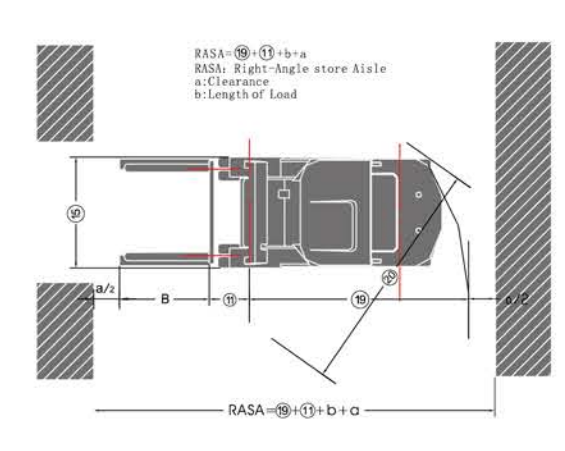
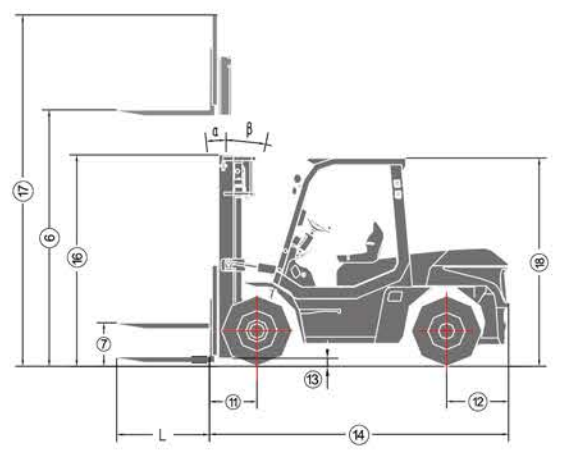
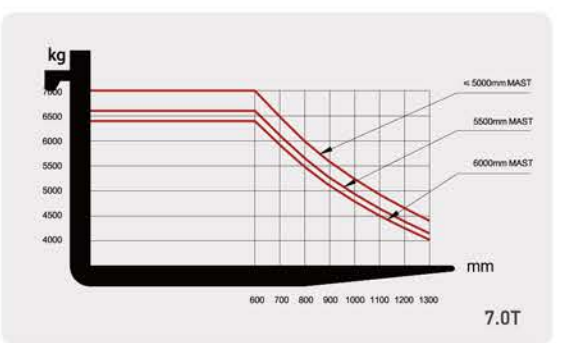
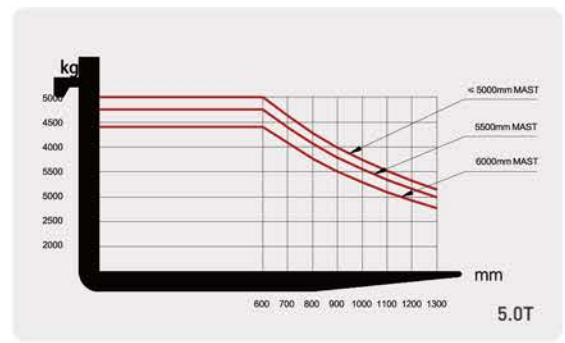

M SERIES 5.0-7.0t mast

Type	Model	Max. fork height	Overall height				Free lift				Front Overhang		Tilt range			Capacity			
			Lowered		Extended		Without backrest		with backrest		5t	7t	FWD	BWD	load capacity at 600mm				
			5t	7t	Without backrest	With backrest	Without backrest	with backrest	5t	7t					kg	kg			
2-stage mast	M350	3500	2750	2875	4400	4500	4870	4870	195	205	195	205	580	590	6	12	5000	7000	
	M400	4000	3050	3175	4900	5000	5370	5370	195	205	195	205	580	590	6	12	5000	7000	
	M450	4500	3300	3425	5400	5500	5870	5870	195	205	195	205	580	590	6	12	5000	7000	
	M500	5000	3550	3675	5900	6000	6370	6370	195	205	195	205	580	590	6	6	5000	7000	
	M550	5500	3850	3975	6400	6500	6870	6870	195	205	195	205	580	590	3	6	4750	6600	
	M600	6000	4100	4225	6900	7000	7370	7370	195	205	195	205	580	590	3	6	4400	6400	
Full free 2-stage mast	FM300	3000			2625		4050		4370		1575		1255	587	597	6	12	5000	7000
	FM330	3300			2775		4350		4670		1725		1405	587	597	6	12	5000	7000
	FM350	3500			2875		4550		4870		1825		1500	587	597	6	12	5000	7000
Full free 3-stage mast	FM400	4000			3175		5050		5370		2125		1800	587	597	6	12	5000	7000
	TFM435	4350			2630		5350		5720		1630		1260	625	635	6	6	4500	6200
	TFM480	4800			2780		5800		6170		1780		1410	625	635	6	6	4500	6200
	TFM500	5000			2880		6000		6370		1880		1510	625	635	3	6	4500	6200
	TFM540	5400			3005		6400		6770		2005		1630	625	635	3	6	4400	6000
	TFM600	6000			3305		7000		7370		2305		1930	625	635	3	6	4200	5500
TFM650	6500			3530		7500		7870		2530		2155	625	635	6	3	6	3900	5100





M SERIES 8.0-compact 12t diesel forklift

General	1	Model	FD80T-M	FD100T-M	FD120T-MX			
		2	Type	Diesel				
	3	Optional type	WF3/WL3/G(4)3					
	4	Rated capacity	8000	10000	12000			
Characteristic&Dimension	5	Load centre	kg	600	600	600		
	6	Lift height	mm	3000	3000	3000		
	7	Free lift height		210	210	210		
	8	Fork size	L×W×T	mm	1220×175×80	1220×175×80	1220×175×83	
	9	Fork regulating range	Min./Max.	mm	340/1970	435/2100	435/2115	
	10	Mast tilt angle	F/R	Deg	6°/12°	6°/12°	6°/12°	
	11	Front overhang		mm	718	718	820	
	12	Rear overhang		mm	740	740	790	
	13	Min. ground clearance(Bottom of mast)		mm	250	250	275	
	14	Length to face of fork (without fork)		mm	4260	4260	4610	
	15	Overall width		mm	2248	2248	2250	
	16	Overall dimensions	Mast lowered height	mm	2850	2850	3015	
	17		Mast extended height(with backrest)	mm	4230	4230	4470	
	18		Overhead guard height	mm	2563	2563	2630	
	19		Turning radius(outside)	mm	3700	3900	4200	
	Performance	20	Min.right angle aisle width (add load length and clearance)	mm	3540	3540	3850	
		21	Speed	Travel(Unladen)	km/h	26/28	26/28	23/26
		22		Lifting(Laden)	mm/s	310	310	340
		23		Lowering(Laden)	mm/s	400	400	360
24		Max. Drawbar pull(Laden/unladen)	KN	58	58	58		
25	Max. Gradeability(Laden)	%	20	20	23			
Tyre	26	Tyre	Front		9.00-20-14PR	9.00-20-14PR	10.00-20-18PR	
	27		Rear		9.00-20-14PR	9.00-20-14PR	10.00-20-18PR	
	28	Tread	Front	mm	1600	1600	1640	
	29		Rear	mm	1700	1700	1880	
Weight	30	Wheelbase	mm	2800	2800	3000		
	31	Self weight	kg	11520	12830	15750		
	32	Weight Distribution	Laden	Front Axle	kg	17200	20380	25080
	33			Rear Axle	kg	2320	2220	2670
	34		Unladen	Front Axle	kg	5100	5700	7400
35	Rear Axle			kg	6420	6900	8350	
Power&Transmission	36	Battery	Voltage/Capacity	V/Ah	2×12/80	2×12/80	2×12/80	
	37	Transmission	Manufacture		China	China	China	
	38		Type		Powershift	Powershift	Powershift	
	39		Stage	F/R		2/2	2/2	2/2
	40	Operating pressure(For attachments)	MPa		19.5	19.5	21	

M SERIES 8.0-10.0t mast

Type	Model	Max. fork height	Overall height				Free lift				Front Overhang		Tilt range		Capacity	
			Lowered		Extended		Without backrest		with backrest		8t	10t	FWD	BWD	load capacity at 600mm	
			8t	10t	Without backrest	With backrest	8t	10t	8t	10t					8t	10t
2-stage mast	M350	3500	3100	3100	4730	—	210	210	—	—	718	718	6	12	8000	10000
	M400	4000	3400	3400	5230	—	210	210	—	—	718	718	6	12	8000	10000
	M500	5000	3900	3900	6230	—	210	210	—	—	718	718	6	6	7750	10000
	M550	5500	4200	4200	6730	—	210	210	—	—	718	718	3	6	7400	9000
	M600	6000	4450	4450	7230	—	210	210	—	—	718	718	3	6	7000	8000
Full free 3-stage mast	TFM450	4500	2900	2900	5780	—	1540	1540	—	—	783	783	6	12	7400	9300
	TFM480	4800	3000	3000	6080	—	1640	1640	—	—	783	783	6	6	6900	8700
	TFM500	5000	3100	3100	6280	—	1740	1740	—	—	783	783	6	6	6750	8700
	TFM540	5400	3225	3225	6680	—	1865	1865	—	—	783	783	3	6	6400	8000
TFM600	6000	3525	3525	7280	—	2165	2165	—	—	783	783	3	6	6000	7000	

M SERIES compact 12t mast

Type	Model	Max. fork height	Overall height			Free lift		Front Overhang	Tilt range		Capacity	
			Lowered	Extended		Without backrest	with backrest		FWD	BWD	load capacity at 600mm	
				X12t	Without backrest			With backrest			X12t	X12t
2-stage mast	M350	3500	3265	4970	—	213	—	820	6	12	12000	
	M400	4000	3565	5470	—	213	—	820	6	12	12000	
	M450	4500	3815	5970	—	213	—	820	6	12	12000	
	M500	5000	4065	6470	—	213	—	820	6	6	11500	
	M550	5500	4365	6970	—	213	—	820	3	6	10500	
Full free 2-stage mast	M600	6000	4615	7470	—	213	—	820	3	6	9500	
	TFM450	4500	3065	6010	—	1540	—	873	6	12	11500	
	TFM480	4800	3165	6310	—	1640	—	873	6	6	10500	
	TFM500	5000	3265	6510	—	1740	—	873	6	6	10500	
TFM540	5400	3405	6910	—	1865	—	873	3	6	10000		
TFM600	6000	3675	7510	—	2165	—	873	3	6	9000		



ISUZU

Type: WF3
 Model: 6BG1QC
 Rated output: 82kw/2000rpm
 Rated torque: 416N.m / 1400-1600rpm
 No. of cylinder: 6
 Bore x Stroke: 105x125mm
 Displacement: 6.494L



CUMMINS

Type: WL3
 Model: QSB4.5-C110(EuIIIA)
 Rated output: 80.9kw/2200rpm
 Rated torque: 488 N.m / 1500rpm
 No. of cylinder: 4
 Bore x Stroke: 107 x 124mm
 Displacement: 4.5L



CHAOCHAI

Type: G(4)3
 Model: CY6BG332-38
 Rated output: 85kw/2200rpm
 Rated torque: 450N.m / 1400-1800rpm
 No. of cylinder: 6
 Bore x Stroke: 102x118mm
 Displacement: 5.785L



CUMMINS

Type: WQ3
 Model: QSB4.5-C130(EuIIIA)
 Rated output: 97kw/2200rpm
 Rated torque: 622 N.m / 1500rpm
 No. of cylinder: 4
 Bore x Stroke: 107 x 124mm
 Displacement: 4.5L

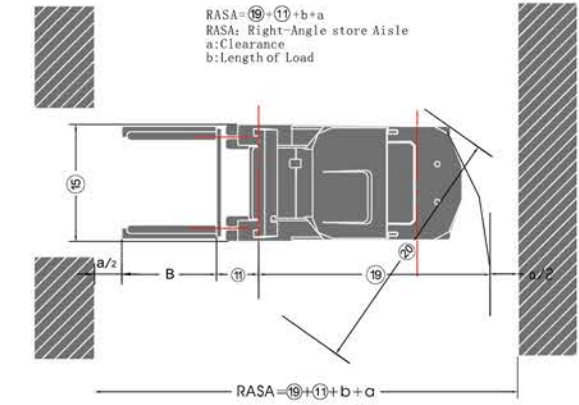
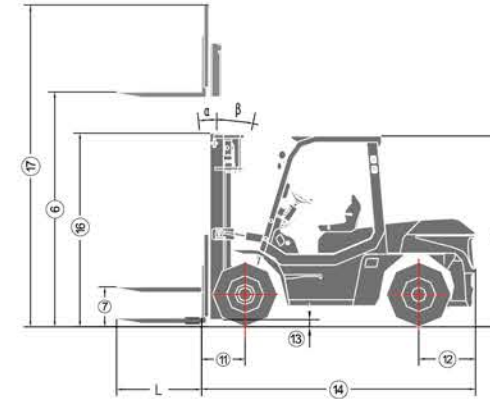

**8.0-compact
 12.0ton
 Diesel forklift**
M SERIES

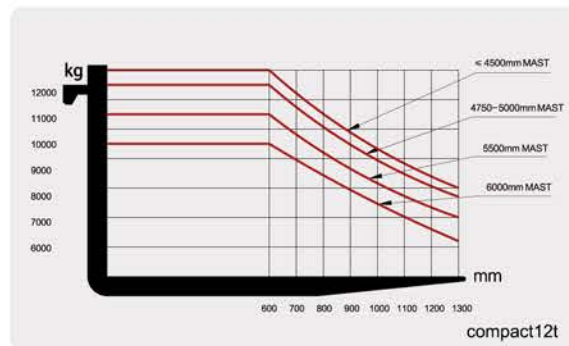
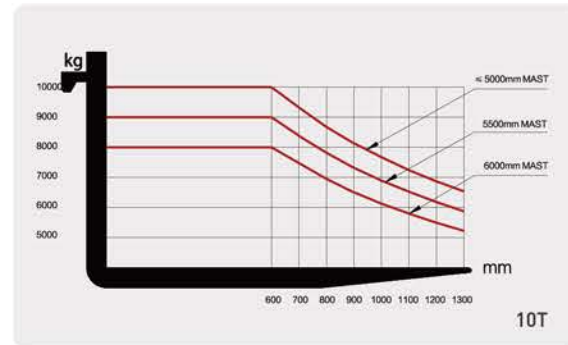
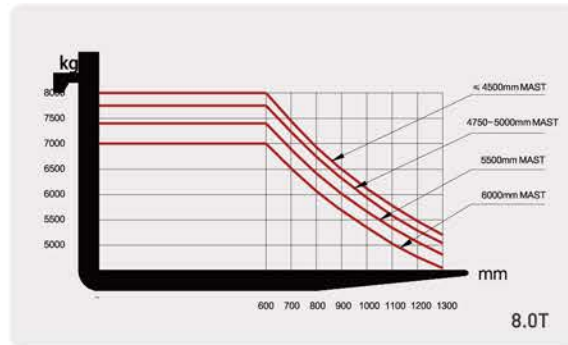



COMPANY MEMORABILIA

2005	Dec	Zhejiang Maximal Forklift Co., Ltd was officially established.
2006	Oct	M series forklifts displayed at the 100th Canton fair.
2007	Nov	Maximal phase I project of the new factory finished.
2008	Jan	Structure of electric forklift was further optimized.
	Nov	Maximal was appointed by the General Logistics Department of the People's Liberation Army(PLA) to be supplier for Military Equipment.
2009	Mar	4.0T&5.0T and 8.0-10.0T diesel forklift were launched to enrich M Series.
	May	Maximal started to prepare the R&D of 16.0-18.0T diesel forklift.
2010	Nov	The first 4.5T electric forklift and 25.0T heavy duty forklift were displayed on Shanghai CeMAT.
	Dec	Maximal and Military Transportation University reached
2012		Maximal was honored as "state-level high-tech enterprise".
2013	May	Maximal 2WD 2.5/3.5T Rough Terrain forklift was launched to the market.
	July	Maximal Empty Container Handler was officially developed.
2014	Jun	Maximal electric stackers & pallet trucks were put into market.
	Aug	Maximal 2WD Rough Terrain forklift were extended to 4.0/5.0T.
	Dec	Maximal phase II project was finished.
2015	May	Maximal 3.5T 4WD Rough Terrain forklift was successfully developed. First Reach Stacker successfully was sold in domestic market.
2016	July	Maximal won the Chinese well-known trademark.
	Oct	1.8-3.5T C. 4WD Hydraulic rough terrain forklift was successfully launched.
2018	July	3.5-4.5T Sider-loader forklift was lanuched; Electric forklift with lithium battery started to be developed; 1.6-2.5T A series Reach truck was lanuched.
	June	Hyster-Yale and Maximal officially completed its acquisition, Maximal began a new start.